

Detail A - Lid Holddown

Detail B - Hinge Attachment

WATERPROOF CONTROL ENCLOSURE			
ENGINEER: E. WILDE	DRAWN BY: E. WILDE		
PAGE: 1 of 2	SCALE: 4:1	SHT SZ: A	
FILE: BOXCTRL	TYPE: STRUCT		
DATE: 94 APR 20	REV:		10

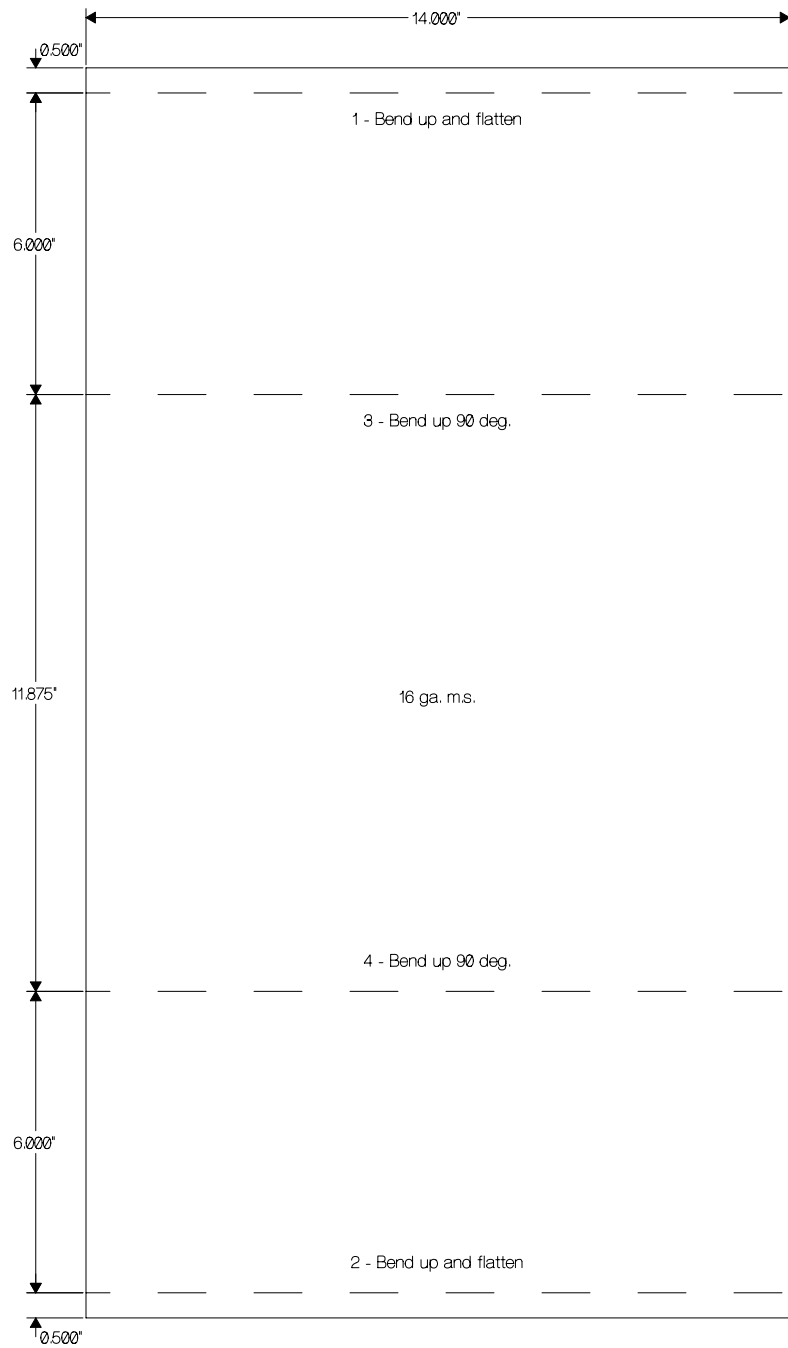

Bottom & Side Layout

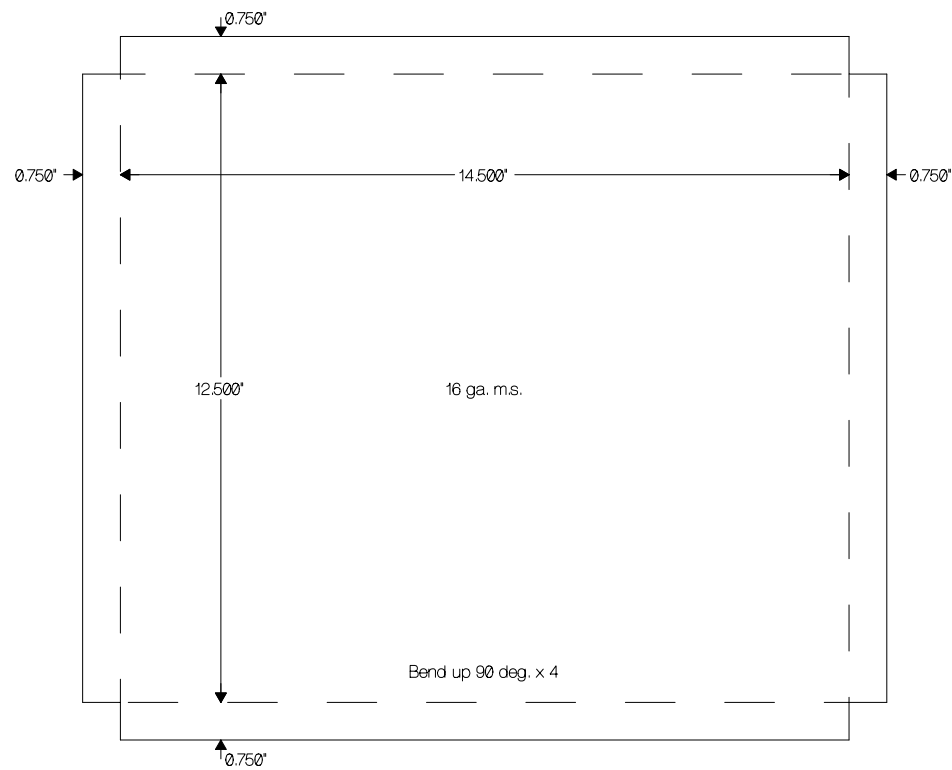

Lid Layout

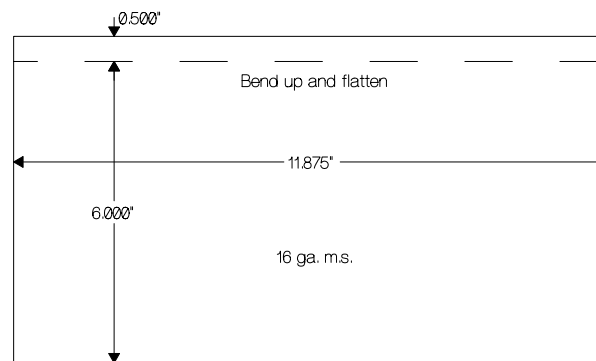

End Layout (2 req.)

WATERPROOF CONTROL ENCLOSURE		
ENGINEER: E. WILDE	DRAWN BY: E. WILDE	
PAGE: 2 of 2	SCALE: 4:1	SHT SZ: A
FILE: BOXCTRL	TYPE: STRUCT	
DATE: 94 APR 20	REV: 1.0	